

Printer 725

μ μ μ μ μ

μ μ Dell:

1.



2.

Dell web: www.dell.com/supplies

3.

μ

μ Dell
μ

μ Dell.
μ μ

" μ ", "

" " "



:

μ



:

μ

μ.

μ



:

μ

μ

.

,

© 2005 Dell Inc.

μ .



Inc. μ Dell

μ μ μ μ : μ *Dell* *DELL*,
μ *Dell Picture Studio* *Dell Ink Management System* μ μ Dell
Inc. μ *Microsoft Windows* μ μ Microsoft
Corporation.

μ μ μ μ μ
μ μ μ μ μ μ μ . Dell Inc.

725

μ 2005 SRV XF819 . A00

;	
<ul style="list-style-type: none"> • μ • 	<p><i>CD Drivers and Utilities</i></p>  <p>Dell,</p> <p>μ μ μ . μ</p> <p>CD μ μ μ .</p> <p>CD μ μ readme μ</p> <p>μ μ μ μ</p>
μ μ	
<ul style="list-style-type: none"> • μ • μ 	

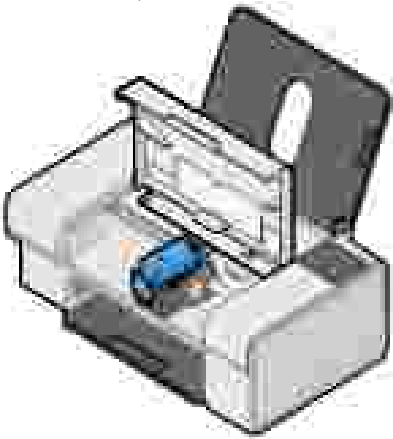
<p>μ</p> <p>μ</p>	<p>μ</p> <p>μ</p>  <p>μ</p> <p>μ</p> <p>:</p> <p>μ</p> <p>μ</p>
-------------------	--

<ul style="list-style-type: none"> • μ • μ • μ 	<p>Dell Web</p> <p>Dell Web online</p> <p>,</p> <ul style="list-style-type: none"> • — μ online μ μ μ , • μ — μ μ , • μ μ • — , • μ — μ • — μ
---	---

<ul style="list-style-type: none"> • μ Windows XP • μ 	<p>Windows XP</p> <ol style="list-style-type: none"> 1. → 2. μ 3. μ μ μ . 4. μ .
---	--

• _____ μ _____

• _____

• _____ μ _____

μ

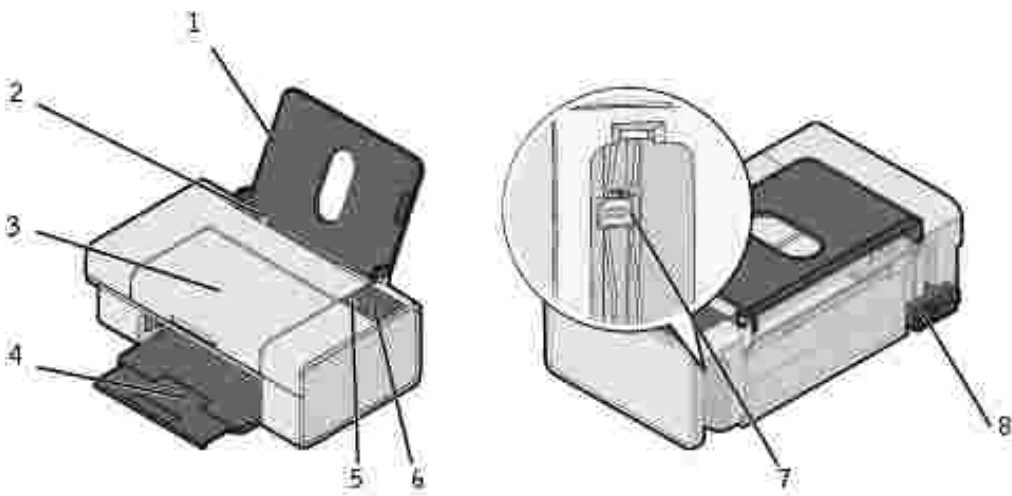

	:	:
1	μ	μ
2		
3	μ	μ μ μ
4		
5	μ	μ

6	μ	μ
7	USB	USB ().
8		USB



Windows XP : Dell Color Printer 725
Windows XP Professional x64 Edition.

Microsoft® Windows® 2000,

μ . μ μ ,
μ .

μ

μ μ :

- μ — μ μ
- **Dell Picture Studio™** — , ,
μ , μ .
- **Dell Ink Management System™** — μ .

μ

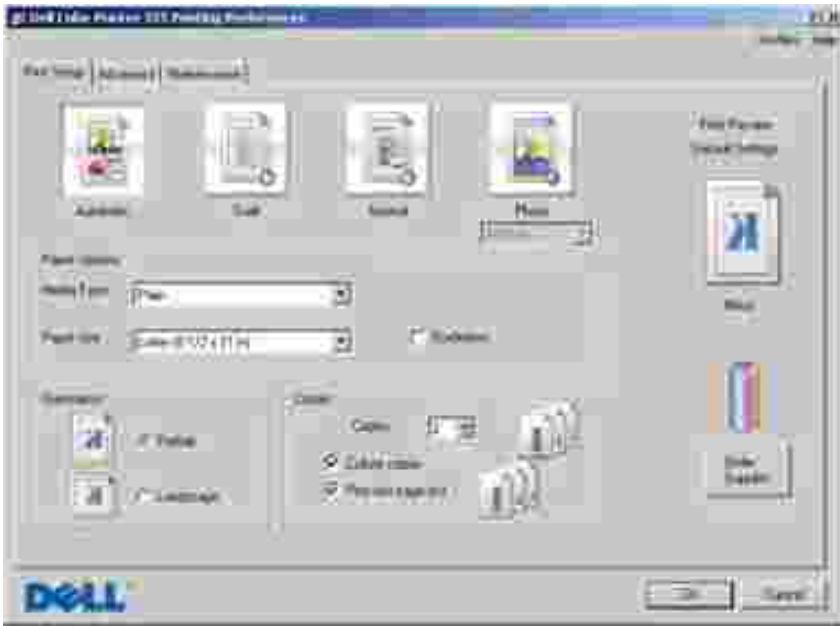

μ

μ

μ

μ

μ

μ

μ

μ

:

1.

,

→

2.

μ

(

μ

μ

μ

,

μ

,

,

μ

μ

μ

:

1.

Windows XP,

→

→

→

Windows 2000,

→

μ

→

2.

μ

μ .



:

μ μ μ μ μ .

μ

μ	/ — μ , , ,
	μ — .
	— μ .
	μ — . μ .
	— μ μ : ,
	, .
μ	—
	. — , Banner , μ , N ,
	, , μ .
	μ μ — μ μ
	μ μ .
	—
	μ .
	μ
	μ
	μ

Dell Picture Studio

Dell Picture Studio, μ

μ

, μ

Dell Picture Studio:

- Paint Shop Photo Album 5

→ μ

Photo Album 5 → Paint Shop Photo Album 5.

μ

→ **Dell Picture Studio 3 → Paint Shop**

- Paint Shop Pro Studio

→ μ

Shop Pro Studio → Jasc Paint Shop Pro Studio.

μ

→ **Dell Picture Studio 3 → Paint**



:

μ

μ

μ

,

μ

μ

μ

μ

.

μ

μ

Dell

μ

, μ

μ

,

μ

μ

μ

μ
50

μ

.

μ

μ

μ

, μ

.

μ

μ

μ

μ

μ , μ

μ

μ

μ μ

μ

μ

μ

μ

.

μ

μ

,

μ.

μ

μ , μ

μ

μ

μ

μ μ .

μ

μ μ μ μ

μ , μ

μ .

1. **Printer 725** → μ **Dell Color Printer 725.** → μ **Dell** → **Dell Color**

2. μ .

3. .

4. *CD Drivers and Utilities* .

μ :

a. *Windows XP,* → μ .

Windows 2000, μ .

b. μ **CD-ROM** . ,
setup.exe.

c. μ μ ,
.

d. μ

- _____
 - _____
 - _____
 - _____ μ
-

1.



2.

μ

3.

μ

μ



:

μ



μ : $\mu \mu \mu$ $\mu \mu$. , μ
 μ (μ μ). μ μ μ μ μ

1. μ .

2. μ μ .

3. \rightarrow .

4. μ μ :

a. μ , μ μ (μ μ).

b. μ , μ μ , / μ , μ μ .

c. μ , μ μ , μ μ μ .

d. **OK** μ

5. **OK** (μ μ μ).

1. μ () μ

2. , → .

3. μ μ (μ μ μ μ μ μ).

μ .

 : μ Dell Picture Studio,™ μ .

4. μ μ (dpi) , μ μ .

5. μ , μ μ .

 : , / .

6. μ μ , **OK.**

7. **OK** (μ μ μ).

8. μ

μ

μ

.



:

μ

(12 24

,

μ

μ

μ

).

μ

.

μ



1.

μ ,

/

μ

.

2.

,

→

.

3.

μ

μ

,

μ

,

,

μ

μ

(

μ

μ

μ

μ).

μ

.

4.

μ

,

μ

(dpi)

μ

μ

.

5.

μ

μ

μ

.

6.

μ

,

μ

μ

μ μ

OK.

7.

OK

(

μ

μ

μ).

μ

- _____ μ
- _____ μ _____ μ
- _____ μ _____ μ



: μ
,
.

μ Dell μ μ Dell.

www.dell.com/supplies

, " μ "

Dell μ Dell . Dell
μ μ μ , μ
Dell.

μ

1. .

2. μ μ.



μ μ μ ,

3. μ μ



4. μ .

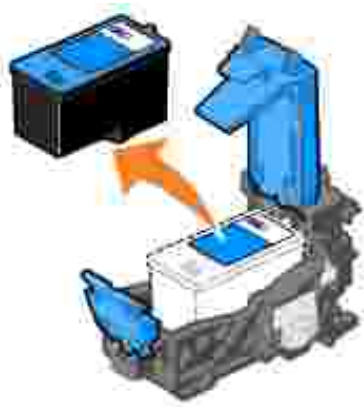

5. μ μ μ .

6. μ ,



7. μ .

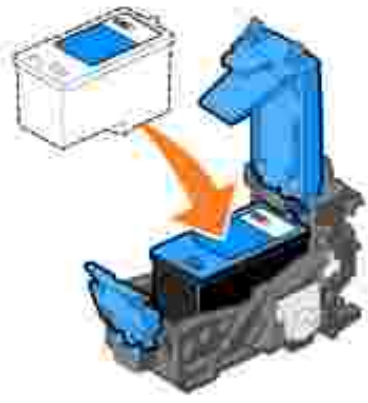

8. .



9. μ μ .

6. μ μ .

7. .

μ μ .

μ μ

μ :

• μ μ μ μ .

• μ μ μ .

• μ , μ .

• μ μ μ .

μ :

1. . ,

_____.

2. Windows XP, → →
→ .

Windows 2000, → μ → .

3. Dell Color Printer 725.

4. μ .

μ .

5. .

6. μ .

7. , **Clean Again.**

8. .

9. μ μ μ μ , .

μ

μ

• μ

• μ

• μ

μ

μ

<p>μ μ .</p> <p>μ Dell Color Printer 725 Windows 2000, Windows XP Windows XP Professional x64 Edition.</p>
<p>USB.</p> <ul style="list-style-type: none"> • USB μ • " , " USB,
<p>μ μ μ μ ,</p> <p>μ μ μ .</p> <ol style="list-style-type: none"> 1. <i>CD Drivers and Utilities.</i> 2. .
<p>μ .</p> <p>→ μ μ → Dell→ Dell</p> <p>Color Printer 725. Dell Color Printer 725 μ</p> <p>μ μ , μ .</p> <p>μ .</p> <p><u>μ</u> .</p>

1. *Windows XP*, → →
→
Windows 2000, → μ →
2. **Dell Color Printer 725** μ

- USB
- USB
- μ

μ

1. *Windows XP*, → →
→
Windows 2000, → μ →
2. **Dell Color Printer 725**
3. μ

μ

μ

μ

μ

	.	
μ	μ	.
μ	μ	.
		μ , μ μ .
		μ
	μ	.
μ	μ	μ :
1.	.	
2.		μ .
3.		.
μ	:	
1.	.	
2.	μ .	
3.		μ .
4.	μ .	
5.		.

μ μ

,

• μ . μ, μ

Dell

- μ μ μ μ Dell bright white.



:

Dell μ μ μ

- .

:

1. , \rightarrow .

2. μ , (μ μ μ) .

3. μ μ , μ μ .

4. .

5. , μ μ μ μ .

μ μ μ μ .

μ .

, μ support.dell.com.

- _____
- _____
- _____ μ _____
- _____
- _____ μ _____
- _____ μ _____
- _____ μ _____
- _____

SDRAM	2 MB
	USB 2.0 ()
(μ)	1.000 μ
	12.000

μ /

	μ	(
	15° 32° C (60° 90° F)	40 80%
	1° 60° C (34° 140° F)	5 80%
	-40° 65° C (-40° 149° F)	5 100%

μ

μ	μ	μ	100–240 VAC
μ			50/60 Hz
	μ	μ	90 VAC
	μ	μ	255 VAC
μ			1,0 A
	μ		2 W 10 W

Dell Color Printer 725 μ

μ

/

μ

	600 x 600 dpi
	1200 x 1200 dpi
	4800 x 1200 dpi

μ

	300 x 600 dpi
	600 x 600 dpi
	1200 x 1200 dpi

μ

Dell Color Printer 725 :

Windows XP Professional x64 Edition

Windows XP

Windows 2000

μ

μ

μ .

μ		RAM (MB)	(MB)
Windows XP Professional x64 Edition	AMD Athlon 64, AMD Opteron, Intel Xeon μ Intel EM64T Intel Pentium 4 μ Intel EM64T	256	500
Windows XP	Pentium 300	128	500
Windows 2000	Pentium 233	128	500

μ

:	:
100	•



μ

μ

μ

μ

20
banner

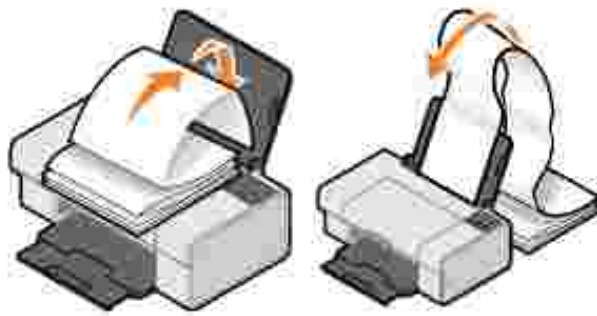

Banner

A4 Banner Letter

μ

•

μ

banner

•

μ

μ

μ

•

banner.

banner

inkjet.

10	<p style="text-align: center;">μ .</p> <ul style="list-style-type: none"> • • • • <p style="text-align: center;">: μ , μ</p>
50	<ul style="list-style-type: none"> • • <p style="text-align: center;">: μ μ</p> <ul style="list-style-type: none"> •

Dell Color Printer 725 μ (USB)
 ().



μ

Dell Color Printer 725

μ

μ

μ

μ

μ

, μ

μ

μ

μ

μ

μ

μ

Internet

www.dell.com/supplies

	877-INK-2-YOU		080-999-0240
	1300 303 290	μ	02,713 1590
	08 20 - 24 05 30 35		1800 88 0553
	02,713 1590		001 866 851 1754
	877-501-4803		020 - 674 4881
	1230-020-3947		231622 64
	800-202874		21 4220710
μ	01800-9-155676		800-858-2425
	+420 225 372 711		022 579 59 65
	3287 5215		866-851-1760
	09 2533 1411		1800 394 7245
	825387247		0860 102 591
μ	0800 2873355		902120385

	1850 707 407		08 587 705 81
	800602705		0848 335 599
	044-556-3551	μ	0870 907 4574



Dell : μ , μ

μ μ . μ

μ	μ
μ μ	JF333

μ Dell

- _____
 - μ μ _____
 - μ Dell
-

μ, Dell

μ

1.

μ

μ

μ

Dell,

μ

μ

μ

μ

μ

μ

μμ.

:

μ

Dell

μ

μ

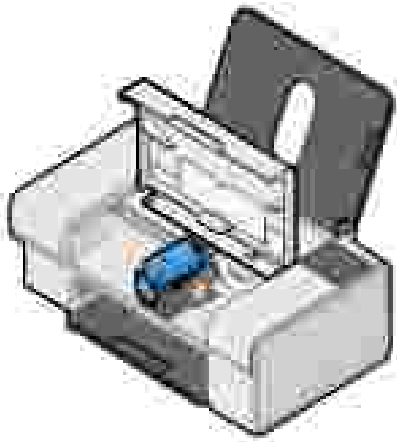

2.

μ

(

)

μ 1-877-459-7298

μ 1-800-624-9896.

μ Dell

μ

3. μ μ μ μ μ

μ μ

Dell, μ

support.dell.com,

μ μ

μ μ μ

μ

μ

Dell

μ

μ

μ **Dell**

μ Dell, μ

:

- **www.dell.com**
- **support.dell.com** ()
- **premiersupport.dell.com** (, μ /μ , μ μ μ Premier, Platinum Gold)

μ web ,

: μ

: μ ,

μ XPS, μ

μ μ μ μ Dell μ μ

Dell XPS μ

μ

μ Dell, μ

μ

μ , μ

()	μ μ μ Web ,	μ μ
		: 800-335-0031
μ		1-800-805-5924
() : 00 : 54 : 11	web: www.dell.com.ar	
	: us_latin_services@dell.com	
	: la-techsupport@dell.com	
	μ EMC®: la_enterprise@dell.com	
		: 0-800-444-0730
		: 0-800-444-0733
		: 0-800-444-0724
		0-810-444-3355
μ		: 800-1578
() : 0011 : 61 : 2	E-mail(): au_tech_support@dell.com	
	(): apcustserv@dell.com	
	μ	1-300-655-533

		: 1-800-633-559
μ μ μ (PAD)		: 1-800-060-889
(μ)		: 1-333-55 (3)
()		: 1-300-655-533
μ (μ)		: 1-800-733-314
		: 1-800-808-385
		: 1-800-808-312
Fax		: 1-800-818-341
()	web: support.euro.dell.com	
: 900	:	
: 43	tech_support_central_europe@dell.com	
: 1	/μ	0820 240 530 00
	Fax /μ	0820 240 530 49
	/μ	0820 240 530 14
μ /	μ μ	0820 240 530 16
	XPS μ	0820 240 530 81
	Dell /μ	0820 240 530 14
μ /	μ μ	0660 8779

		0820 240 530 00
μ		: 1-866-278-6818
μ		1-800-534-3066
()	web: support.euro.dell.com	
: 00	E-mail : support.euro.dell.com/be/fr/emaildell/	
: 32	XPS	02 481 92 96
: 2	Dell	02 481 92 88
	Fax	02 481 92 95
		02 713 15 65
		02 481 91 00
	Fax	02 481 92 99
		02 481 91 00
μ		1-800-342-0671
		: 800-10-0238
	web: www.dell.com/br	
: 00	,	0800 90 3355
: 55	Fax	51 481 5470
: 51	Fax	51 481 5480
		0800 90 3390
		: 1-866-278-6820
: 673	(,)	604 633 4966
	(,)	604 633 4888
	(,)	604 633 4955

<p>()</p> <p>: 011</p>	<p>www.dell.ca/ostatus</p> <p>AutoTech (μ μ)</p> <p>/μ ()</p> <p>(μ /μ)</p> <p>/μ ()</p> <p>(μ /μ)</p> <p>(, μ μ)</p> <p>(/μ)</p> <p>(μ /μ)</p> <p>μ &</p>	<p>:</p> <p>: 1-800-247-9362</p> <p>: 1-800-847-4096</p> <p>: 1-800-326-9463</p> <p>: 1-800-847-4096</p> <p>: 1-800-387-5757</p> <p>1-877-335-5767</p> <p>: 1-800-387-5752</p> <p>: 1-800-387-5755</p> <p>1 866 440 3355</p>
<p>μ</p>		<p>1-800-805-7541</p>
<p>()</p> <p>: 56</p> <p>: 2</p>	<p>,</p>	<p>: 1230-020-4823</p>
<p>(Xiamen)</p> <p>: 86</p> <p>: 592</p>	<p>web:</p> <p>support.dell.com.cn</p> <p>: cn_support@dell.com</p> <p>: customer_cn@dell.com</p> <p>Fax</p>	<p></p>

Inspiron) (Dell™ Dimension™	: 800 858 2969
Dell Precision™) (OptiPlex™, Latitude™	: 800 858 0950
(μ)	: 800 858 0960
(, μ , .) , PDA,	: 800 858 2920
()	: 800 858 2311
	: 800 858 2060
Fax	592 818 1308
μ	: 800 858 2222
μ μ μ μ μ	: 800 858 2557
μ GCP	: 800 858 2055
μ μ μ	: 800 858 2628
μ -	: 800 858 2999
μ -	: 800 858 2955
μ -	: 800 858 2020
μ -	: 800 858 2669
μ - μ	: 800 858 2572

	μ -	: 800 858 2355
	μ -	: 800 858 2811
	μ -	: 800 858 2621
μ		980-9-15-3978
		0800-012-0435
μ () : 00 : 420	web: support.euro.dell.com	
	:	
	czech_dell@dell.com	
		22537 2727
		22537 2707
	Fax	22537 2714
	Fax μ μ	22537 2728
	22537 2711	
() : 00 : 45	web: support.euro.dell.com	
	:	
	support.euro.dell.com/dk/da/emaildell/	
	XPS	7010 0074
	Dell	7023 0182
	()	7023 0184
	/μ	3287 5505
	()	3287 1200
	Fax ()	3287 1201
	(/μ)	3287 5000

	Fax (/μ)	3287 5001
μ		: 1-866-278-6821
μ μ		1-800-148-0530
		: 999-119
		01-899-753-0777
()	web: support.euro.dell.com	
: 990	:	
: 358	support.euro.dell.com/fi/fi/emaildell/	
: 9		09 253 313 60
		09 253 313 38
	Fax	09 253 313 99
		09 253 313 00
() ()	web: support.euro.dell.com	
: 00	:	
: 33	support.euro.dell.com/fr/fr/emaildell/	
: (1) (4)	μ	
	XPS	0825 387 129
	Dell	0825 387 270
		0825 823 833
		0825 004 700
	()	04 99 75 40 00
		0825 004 700
	Fax	0825 004 701
	Fax ()	04 99 75 40 01

		0825 004 719
		0825 338 339
		01 55 94 71 00
		01 55 94 71 00
	Fax	01 55 94 71 01
<p>μ ()</p> <p>: 00</p> <p>: 49</p> <p>: 6103</p>	web: support.euro.dell.com	
	:	
	tech_support_central_europe@dell.com	
	XPS	06103 766-7222
	Dell	06103 766-7200
	/μ	0180-5-224400
	μ μ μ	06103 766-9570
	μ μ	06103 766-9420
	μ μ	06103 766-9560
	μ μ	06103 766-9555
		06103 766-7000
<p>: 00</p> <p>: 30</p>	web: support.euro.dell.com	
	:	
	support.euro.dell.com/gr/en/emailldell/	
		00800-44 14 95 18
	" "	00800-44 14 00 83
		2108129810
" "	2108129811	

		2108129800
	Fax	2108129812
		: 1-866-540-3355
μ		1-800-999-0136
		: 1-877-270-4609
: 001 : 852	web: support.ap.dell.com	
	: apsupport@dell.com	
	(Dimension Inspiron)	2969 3188
	(OptiPlex, Latitude Dell Precision)	2969 3191
	(PowerApp™, PowerEdge™, PowerConnect™ PowerVault™)	2969 3196
		3416 0910
	μ	3416 0907
	μ μ μ	3416 0908
	μ μ μ	3416 0912
	μ μ μ	2969 3105
	: india_support_desktop@dell.com india_support_notebook@dell.com india_support_Server@dell.com	
		1600 33 8045 1600 44 8046
	(μ)	1600 33 8044
	(μ)	1600 33 8046
()	web: support.euro.dell.com	

	:	
: 16	dell_direct_support@dell.com	
: 353	XPS	1850 200 722
: 1	Dell	1850 543 543
	. . (μ	0870 908 0800
	. .)	
		01 204 4014
	μ	01 204 4014
	. . (μ	0870 906 0010
	. .)	
		1850 200 982
	(0870 907 4499
	μ . .)	
		01 204 4444
	. . (μ . .)	0870 907 4000
	Fax/Fax	01 204 0103
		01 204 4444
()	web: support.euro.dell.com	
: 00	:	
: 39	support.euro.dell.com/it/it/emaildell/	
: 02	μ	
		02 577 826 90
		02 696 821 14
	Fax	02 696 821 13
		02 696 821 12
		02 577 826 90

		02 577 825 55
	Fax	02 575 035 30
		02 577 821
μ	(μ)	1-800-682-3639
()	web: support.jp.dell.com	
: 001	(μ)	: 0120-198-498
: 81	(μ)	81-44-556-4162
: 44	(Dimension Inspiron)	: 0120-198-226
	(Dimension Inspiron)	81-44-520-1435
	(Dell Precision, OptiPlex Latitude)	: 0120-198-433
	(Dell Precision, OptiPlex Latitude)	81-44-556-3894
	(PDA, μ)	: 0120-981-690
	(PDA, μ)	81-44-556-3468
	Faxbox	044-556-3490
24	μ μ	044-556-3801
		044-556-4240
μ μ	(400)	044-556-1465
μ μ	(μ μ 400)	044-556-3433
(μ 3500)	μ	044-556-3430

	μ (, μ)	044-556-1469
	μ	044-556-3469
	μ μ	044-556-1760
		044-556-4300
()	: krsupport@dell.com	
: 001		: 080-200-3800
: 82	(Dimension, PDA, μ)	: 080-200-3801
: 2		: 080-200-3600
	Fax	2194-6202
		2194-6000
μ	(, , . . .)	512 728-4093
	(, , . . .)	512 728-3619
	Fax () (, , . . .)	512 728-3883
	(, , . . .)	512 728-4397
	Fax (, , . . .)	512 728-4600
		512 728-3772
μ	web: support.euro.dell.com	
		342 08 08 075
: 00	/μ	+32 (0)2 713 15 96
: 352		26 25 77 81
		+32 (0)2 481 91 19
	Fax	26 25 77 82

		: 0800 105
: 853	(Xiamen,)	34 160 910
	(Xiamen,)	29 693 115
()	web: support.ap.dell.com	
: 00	(Dell Precision, OptiPlex Latitude)	: 1 800 880 193
: 60	(Dimension, Inspiron μ)	: 1 800 881 306
: 4	(PowerApp, PowerEdge, PowerConnect PowerVault)	: 1800 881 386
		: 1800 881 306 (6)
		: 1 800 888 202
		: 1 800 888 213
: 00		001-877-384-8979 001-877-269-3383
: 52		50-81-8800 01-800-888-3355
		001-877-384-8979 001-877-269-3383
		50-81-8800 01-800-888-3355
		: 1-866-278- 6822
		001-800-882-1519
	web: support.euro.dell.com	

(μ : 00 : 31 : 20	XPS	020 674 45 94
	Dell	020 674 45 00
	Fax	020 674 47 66
	/μ	020 674 42 00
		020 674 43 25
	/μ	020 674 55 00
		020 674 50 00
	Fax /μ	020 674 47 75
	Fax	020 674 47 50
		020 674 50 00
	Fax	020 674 47 50
	: 00 : 64	E-mail (): nz_tech_support@dell.com
(): apcustserv@dell.com		
		: 0800 289 335 (3)
()		: 0800 446 255
(μ) μ		: 0800 443 563
μ		0800 446 255
		0800 444 617
		0800 441 567
Fax		0800 441 566

		001-800-220-1006
(Lysaker) : 00 : 47	web: support.euro.dell.com	
	:	
	support.euro.dell.com/no/no/emaildell/	
	XPS	815 35 043
	Dell	671 16882
		671 17575
	/μ	231 62298
	Fax	671 16800 671 16865
μ		001-800-507-0962
		0800-50-669
() : 011 : 48 : 22	web: support.euro.dell.com	
	:	
	pl_support_tech@dell.com	
		57 95 700
		57 95 999
		57 95 999
	Fax	57 95 806
	Fax	57 95 998
	57 95 999	
: 00 : 351	web: support.euro.dell.com	
	:	
	support.euro.dell.com/pt/en/emaildell/	
		707200149
		800 300 413

		800 300 410 800 300 411 800 300 412 21 422 07 10
	Fax	21 424 01 12
		1-800-805-7545
.		: 1-877-441-4731
.		1-800-882-1521
.		: 1-877-270-4609
() : 005 : 65	web: support.ap.dell.com	
	(Dimension, Inspiron μ)	: 1800 394 7430
	(OptiPlex, Latitude Dell Precision)	: 1800 394 7488
	(PowerApp, PowerEdge, PowerConnect PowerVault)	: 1800 394 7478
		: 1800 394 7430 (6)
		: 1800 394 7412
		: 1800 394 7419
() : 00 : 421	web: support.euro.dell.com	
	:	
	czech_dell@dell.com	
		02 5441 5727
		420 22537 2707
	Fax	02 5441 8328
Fax μ μ	02 5441 8328	

	()	02 5441 7585
(μ) : 09/091 : 27 : 11	web: support.euro.dell.com	
	:	
	dell_za_support@dell.com	
		011 709 7713
		011 709 7710
		011 709 7707
		011 709 7700
	Fax	011 706 0495
	011 709 7700	
	(,)	604 633 4810
() : 00 : 34 : 91	web: support.euro.dell.com	
	:	
	support.euro.dell.com/es/es/emaildell/	
	μ	
		902 100 130
		902 118 540
		902 118 541
		902 118 541
	Fax	902 118 539
		902 100 130
		902 115 236
		91 722 92 00
Fax	91 722 95 83	
(Upplands	web: support.euro.dell.com	

Vasby) : 00 : 46 : 8		:	
		support.euro.dell.com/se/sv/emaildell/	
		XPS	0771 340 340
		Dell	08 590 05 199
			08 590 05 642
		/μ	08 587 70 527
		μ (EPP)	20 140 14 44
		Fax	08 590 05 594
() : 00 : 41 : 22		web: support.euro.dell.com	
		:	
		Tech_support_central_Europe@dell.com	
		E-mail (, μ μ): support.euro.dell.com/ch/fr/emaildell/	
		XPS	0848 33 88 57
		(μ) Dell	0844 811 411
		()	0844 822 844
		(μ)	0848 802 202
		()	0848 821 721
		Fax	022 799 01 90
			022 799 01 01
	web: support.ap.dell.com		

<p>: 002</p> <p>: 886</p>	<p>ap_support@dell.com</p> <p>(OptiPlex, Latitude, Inspiron, Dimension μ)</p> <p>(PowerApp, PowerEdge, PowerConnect PowerVault)</p>	<p></p> <p>: 00801 86 1011</p> <p>: 00801 60 1256</p> <p>: 00801 60 1250 (5)</p> <p>: 00801 65 1228</p> <p>: 00801 65 1227</p>
<p>: 001</p> <p>: 66</p>	<p>web: support.ap.dell.com</p> <p>(OptiPlex, Latitude Dell Precision)</p> <p>(PowerApp, PowerEdge, PowerConnect PowerVault)</p>	<p></p> <p>: 1800 0060 07</p> <p>: 1800 0600 09</p> <p>: 1800006 007 7)</p> <p>: 1800 006 009</p> <p>: 1800 006 006</p>
<p>/ μ</p>		<p>1-800-805-8035</p>
		<p>: 1-866-540-3355</p>
<p>μ</p>	<p>web: support.euro.dell.com</p>	

()

: 00

: 44

: 1344

		support.euro.dell.com/uk/en/ECare/Form/Home.asp
		dell_direct_support@dell.com
(/ μ μ μ /PAD [1000+])		0870 908 0500
XPS		0870 366 4180
(μ)		0870 908 0800
μ	μ	01344 373 186
	μ	0870 906 0010
		01344 373 185
μ (500–5000 μ μ)		0870 906 0010
		01344 373 193
&		01344 373 199
		01344 373 194
	μ	0870 907 4000
	/ μ μ	01344 860 456
Fax	μ	0870 907 4006
		: 000-413-598-2521
. . . (,)	μ μ	: 1-800-433-9014

: 011

: 1

AutoTech()	: 1-800-247-9362
(Dell TV,)	1-877-459-7298
()	
Dell	: 1-800-624-9896
	: 1-800-624-9897
DellNet™	: 1-877-Dellnet (1-877-335-5638)
μ (EPP)	: 1-800-695-8133
μ web: www.dellfinancialservices.com	
μ (μ /)	: 1-877-577-3355
μ (μ μ μ Dell [DPA])	: 1-800-283-2210
	: 1-800-456-3355
μ (EPP)	: 1-800-695-8133
	: 1-877-459-7298
μ (,)	
	: 1-800-456-3355
μ (EPP)	: 1-800-695-8133

	Dell	: 1-800-289-3355
		: 1-800-879-3355
	μ Dell (μ Dell)	: 1-888-798-7561
	μ	: 1-800-671-3355
		: 1-800-357-3355
	μ	: 1-800-247-4618
	Fax	: 1-800-727-8320
	Dell μ μ μ	: 1-877-DELLTTY (1-877-335-5889)
(. . .)		1-877-673-3355
		8001-3605

, μ /

Dell μ

DellT

μ

,

μ μ
μ μ , μ

μ

μ μ μ :

• A, μ

μ

• B, μ

μ

/

μ ,

,

,

μ μ

,

,

μ

μ μ

μ

:

μ

μ.

DellT Inc. μ

μ

μ

μ

μ :

DellT ,
μ

μ

μ

μ

μ

μ

μ

μ

DellT. μ

μ , μ
www.dell.com.

B.

DellT μ

World Wide Web

DellT

μ

μ

μ

,

μ

μ

μ

Dell

μ μ μ EMI/EMC.

μ

μ

μ

CE ()

,

DellT

B

μ

μ

" μ " μ μ
DellT Inc. Products Europe BV, Limerick,
Ireland.

μ μ **ENERGY STAR®**

Dell ENERGY STAR®

. . . (EPA) ENERGY STAR® Dell.
μ μ μ μ μ μ
μ , .

μ
μ (WEEE)



μ , μ
μ
: www.euro.dell.com/recycling.

(W.



www.euro.dell.com/recycling.

Diretiva WEEE (Waste from Electrical and Electronic Equipment)



Na União Europeia, essa etiqueta indica que o produto não deve ser descartado junto com o lixo normal. Ele deve ser depositado em uma instalação apropriada para coleta e reciclagem. Para obter informações sobre como reciclar este produto de forma responsável em seu país, visite: www.euro.dell.com/recycling.

Smernice o odpadních elektrických a elektronických zařízeních (WEEE)



V Evropské unii tento štítek označuje, že tento produkt nesmí být likvidován s běžným komunálním odpadem. Je třeba předat jej do příslušného zařízení za účelem renovace a recyklace. Informace o recyklaci tohoto produktu ve vaší zemi naleznete na adrese: www.euro.dell.com/recycling.

WEEE-direktiv (Waste from Electrical and Electronic Equipment)



I EU angiver denne etiket, at produktet ikke må bortskaffes sammen med husholdningsaffald. Det skal afleveres på en facilitet, som er ansvarlig for gendannelse og genbrug. Oplysninger om ansvarlig genbrug af dette produkt i dit land finder du på : www.euro.dell.com/recycling.

Richtlijn WEEE, afdanken van elektrische en elektronische apparaten



In de Europese Unie geeft dit label aan dit product niet via huishoudelijk afval mag worden afgedankt. Het moet gedeponerd worden bij een daarvoor geschikte voorziening zodat recuperatie en recyclage mogelijk zijn. Raadpleeg voor informatie over de milieuvriendelijke wijze van recyclage van dit product in uw land: www.euro.dell.com/recycling.

Waste Electrical and Electronic Equipment (WEEE) Directive



In the European Union, this label indicates that this product should not be disposed of with household waste. It should be deposited at an appropriate facility to enable recovery and recycling. For information on how to recycle this product responsibly in your country, please visit: www.euro.dell.com/recycling.

WEEE-direktiivi käytöstä poistettujen laitteiden hävittämisestä



Euroopan unionissa tämä merkintä kertoo, että tuote tulee hävittää kotitalousjätteen mukana. Se tulee hävittää niin, että se voidaan noutaa ja siirtää kierrätykseen. Lisätietoja maakohtaisesta jätteenkäsittelyohjeista on sivustossa www.euro.dell.com/recycling.

Directive sur les déchets d'équipements électriques et électroniques (DEEE)



Dans l'Union européenne, cette étiquette indique que le produit ne doit pas être mis au rebus avec des déchets ménagers. Vous devez le déposer dans un lieu destiné à la récupération et au recyclage de tels déchets. Pour de plus amples informations sur le recyclage de ce produit dans votre pays, vous pouvez consulter notre site à l'adresse suivante : www.euro.dell.com/recycling.

Richtlinie für Abfall von elektrischen und elektronischen Geräten (WEEE)



In der Europäischen Union bedeutet diese Markierung, dass dieses Produkt nicht mit dem Hausmüll entsorgt werden sollte. Es sollte zu einer sachgemäßen Einrichtung gebracht werden, um Wiedergewinnung und Recycling zu ermöglichen. Weitere Informationen über das verantwortungsbewusste Recyceln dieses Produkts erhalten Sie unter: www.euro.dell.com/recycling.

Waste Electrical and Electronic Equipment (WEEE) Directive



www.euro.dell.com/recycling.

Direttiva WEEE (Waste from Electrical and Electronic Equipment)



Nell'Unione Europea, questa etichetta indica che il prodotto non deve essere smaltito insieme ai rifiuti solidi urbani. Il prodotto deve essere depositato in un impianto appropriato per consentirne il recupero e il riciclaggio. Per informazioni su come riciclare questo prodotto in modo responsabile nel paese di appartenenza, visitare il sito all'indirizzo: www.euro.dell.com/recycling.

EE-direktivet (direktivet om elektrisk og elektronisk avfall)



I EU indikerer dette merket at dette produktet ikke skal kastes sammen med vanlig restavfall. Det bør avhendes ved et egnet anlegg slik at det kan gjenvinnes og resirkuleres. Du finner mer informasjon om hvordan du kan resirkulere dette produktet på en sikker måte i ditt land, på www.euro.dell.com/recycling.

Dyrektywa w sprawie zużytego sprzętu elektrycznego i elektronicznego (WEEE)



W Unii Europejskiej etykieta ta oznacza, że tego produktu nie należy wyrzucać wraz z odpadami z gospodarstwa domowego. Należy go przekazać do odpowiedniego zakładu, gdzie zostanie poddany odzyskowi i recyklingowi. Informacje o sposobie odpowiedzialnego recyklingu tego produktu w danym kraju można znaleźć pod adresem www.euro.dell.com/recycling.

(WEEE)



www.euro.dell.com/recycling.

Directiva sobre el desecho de material eléctrico y electrónico (WEEE)



En la Unión Europea, esta etiqueta indica que la eliminación de este producto no se puede hacer junto con el desecho doméstico. Se debe depositar en una instalación apropiada que facilite la recuperación y el reciclado. Para obtener más información sobre cómo reciclar este producto de manera responsable en su país, visite el sitio Web: www.euro.dell.com/recycling.

WEEE-direktivet (Waste from Electrical and Electronic Equipment)



Inom EU indikerar den här etiketten att produkten får inte slängas med hushållsavfall. Den ska lämnas in på en återvinningsstation. Information om hur produkten återvinns i ditt land finns på:

www.euro.dell.com/recycling.

Atik Elektrikli ve Elektronik Donanimlar (WEEE) Direktifi



Avrupa Birliğinde, bu etiket bu ürünün ev atıkları ile birlikte atılmaması gerektiğini belirtir.

Kurtarılabilmesi ve geri dönüştürülebilmesi için uygun bir tesise bırakılmalıdır. Bu ürünün ülkenizde sorumlu bir şekilde nasıl geri dönüştürüleceği ile ilgili bilgiler için, lütfen bu web adresini ziyaret edin:

www.euro.dell.com/recycling.

www.dell.com/ap/ (μ /)
www.euro.dell.com (μ)
www.dell.com/la/ (μ)
www.dell.com/jp (μ)

- μ FTP
ftp.dell.com/
μ μ : anonymous μ

- mobile_support@us.dell.com
support@us.dell.com
apsupport@dell.com (μ /)
support.euro.dell.com (μ)
support.jp.dell.com/jp/jp/tech/email/ (μ)

- μ
sales@dell.com
apmarketing@dell.com (μ /)

- info@dell.com

Dell Inc. (μ "Dell") μ μ
μ μ μ
μ μ μ
μ μ μ Dell

μ

μ

μ μ μ :

• μ Dell / μ

• μ μ Dell μ μ μ
GNU, 2, μ μ
GNU, 2.1 μ

• μ μ μ μ BSD

:

• [BSD](#)

• [GNU](#)

μ μ Dell μ μ
μ . μ / μ μ

μ μ Dell μ μ

μ μ Dell

Dell μ , μ , μ ,
μ . μ ,
μ .

Dell, μ μ μ
μ *CD Drivers and Utilities CD* μ μ μ
μ Dell " μ Dell" .